

1. smc5d-m4 central unit

1.1. Technical specifications:

- Power: 24V DC, 300mA
- Ethernet 100 Mbit connector - **recommended cat. 6A** or higher cable.
- USB HS connector - **good quality cable, with ferrite choke recommended.**
- CAN bus connector - for connecting additional extension modules.
- 6 axes (X,Y,Z,A,B,C) with differential outputs, up to 300 kHz step frequency.
- 4 relay outputs, galvanically isolated, in two separate groups, one of the groups can be switched to OC or 0/+5V DC mode.
maximum values for relays: 1A/30V DC, 0.5A/125V AC
maximum current for OC mode: 300 mA DC
maximum current for voltage mode 0/5V DC: 100 mA
- Additional output limiting motor current, operating in two modes OC or 0/+5V.
- 8 opto-isolated inputs with led
- Handwheel operator panel connector.
- 2 separate and galvanically isolated connectors from the red switch in the Handwheel operator panel.
- Micro SD card connector.
- Protection against too high supply voltage and reverse power connection.
- Housing designed for DIN rail mounting, length: 155mm, width: 86mm, thickness: 30mm.

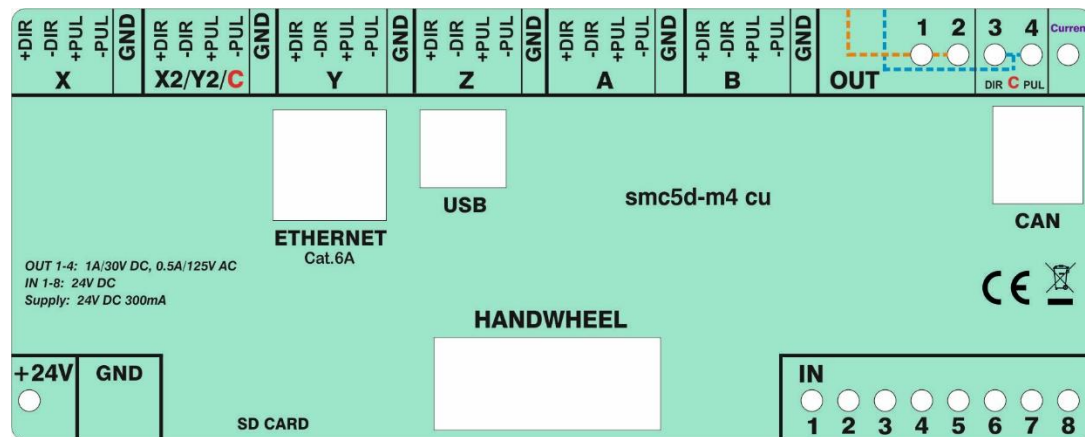

Fig. 1 View of the front panel of the central unit

1.2. Central unit - external connections and internal operating mode settings:

The figures below shows the connection and jumper settings of central unit.

Note: **jumpers are available after removing the cover.**

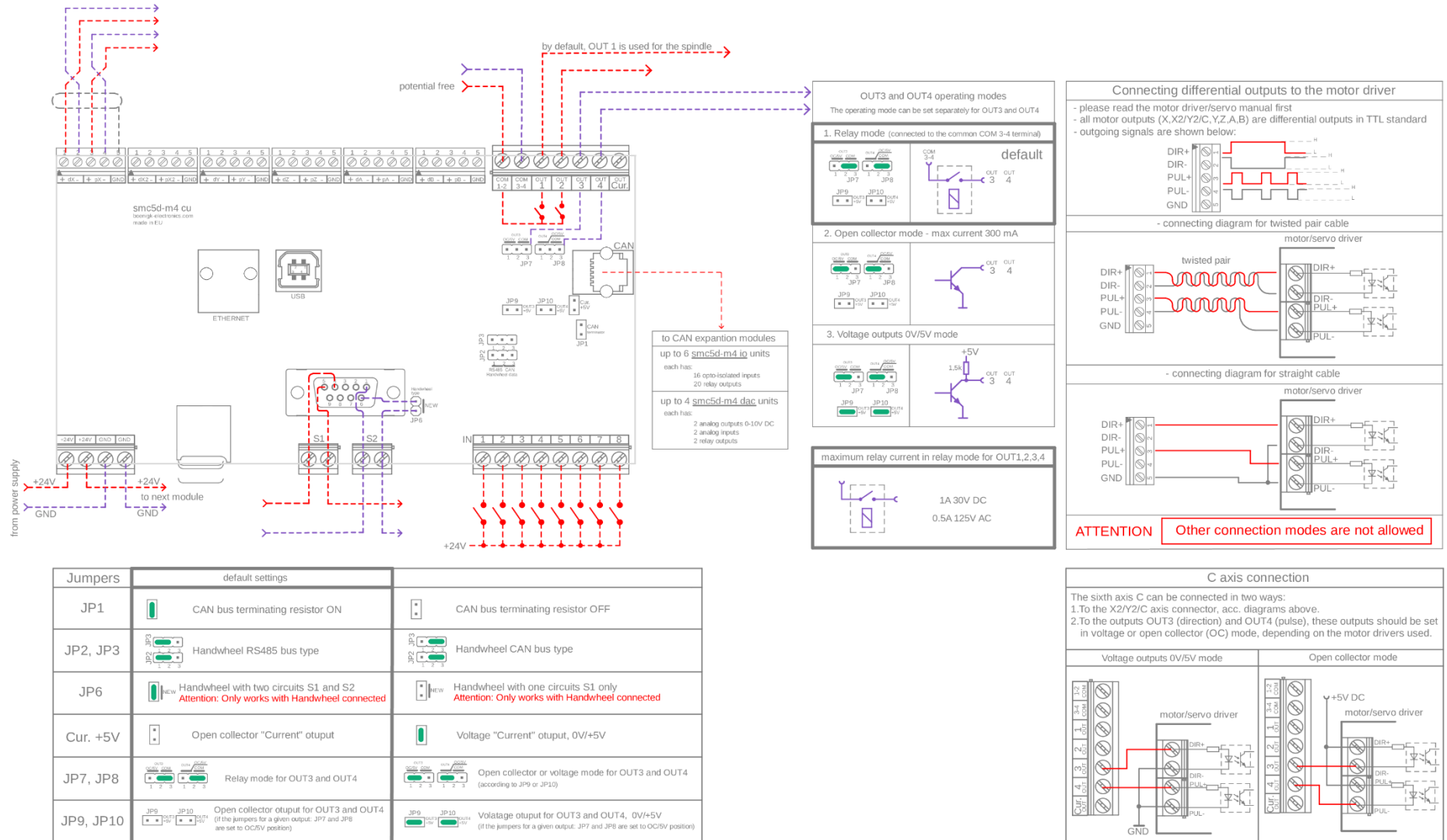

Fig. 2 Electrical wiring diagram and location of jumpers

2. smc5d-m4 io

2.1. Technical specifications:

- Power: 24V DC, 400mA
- 2 CAN bus connectors
- 20 relay outputs, galvanically isolated, in two separate groups of 10 output each.
Maximum values for relays: 1A/30V DC, 0.5A/125V AC
- 16 opto-isolated inputs.
- Protection against too high supply voltage and reverse power connection.
- Housing designed for DIN rail mounting, length: 155mm, width: 86mm, thickness: 30mm.

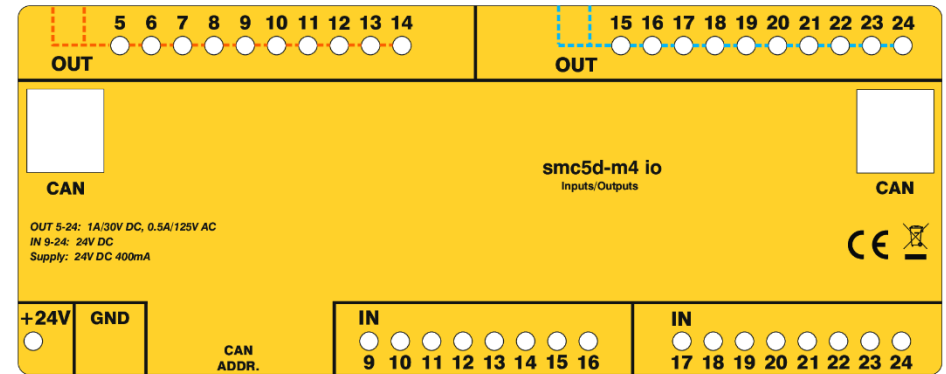

Fig. 3 View of the front panel of the io module

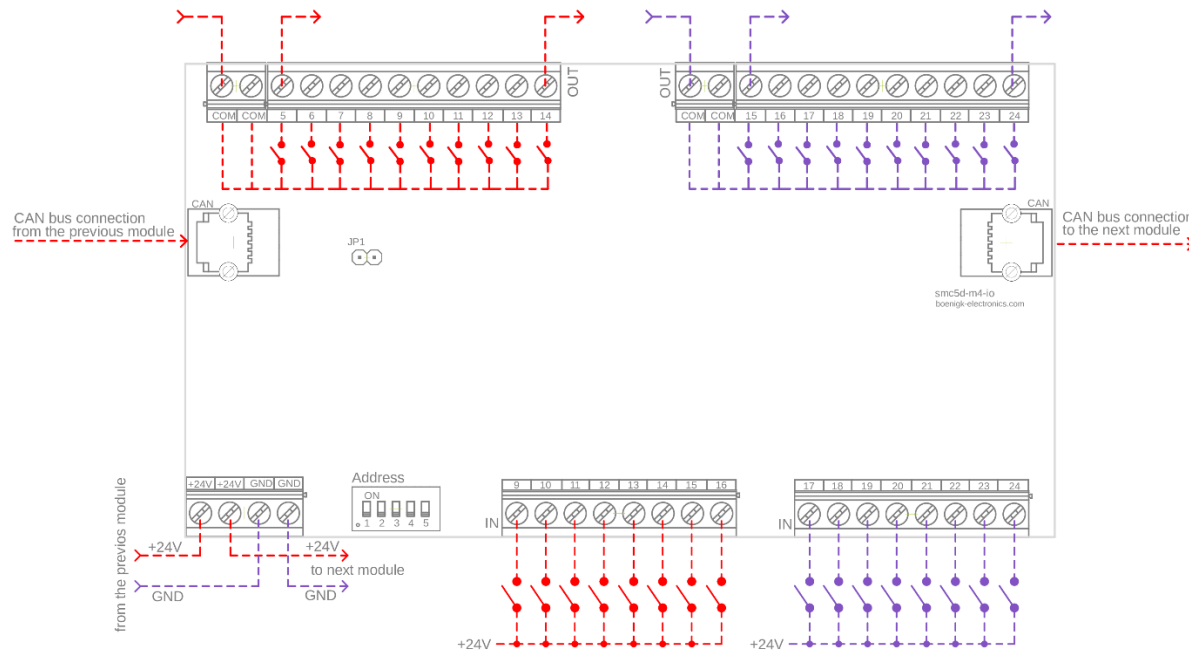

Fig. 4 Electrical wiring diagram and location of jumper

3. smc5d-m4 dac

3.1. Technical specifications:

- Power: 24V DC, 100mA.
- 2 CAN bus connectors.
- 2 Analog outputs 0-10V DC 20mA (0-5V DC or PWM - depending on jumper settings) with fine-tune possibility.
- 2 Analog inputs 0-13V DC – accuracy 0.02V.
- 2 relay outputs, galvanically isolated, maximum values for relays: 1A/30V DC, 0.5A/125V AC.
- Protection against too high supply voltage and reverse power connection.
- Housing designed for DIN rail mounting, length: 86mm, width: 86mm, thickness: 30mm.

Note 1:

The yellow power LED flashes when the dac module has no communication with the central unit.

Note 2:

R1 and R2 potentiometers are used to precisely set the 10 V voltage - separately for each channel.

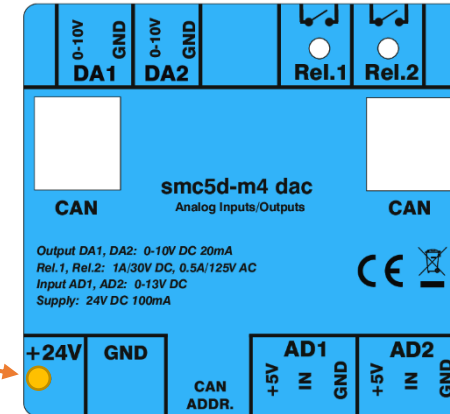
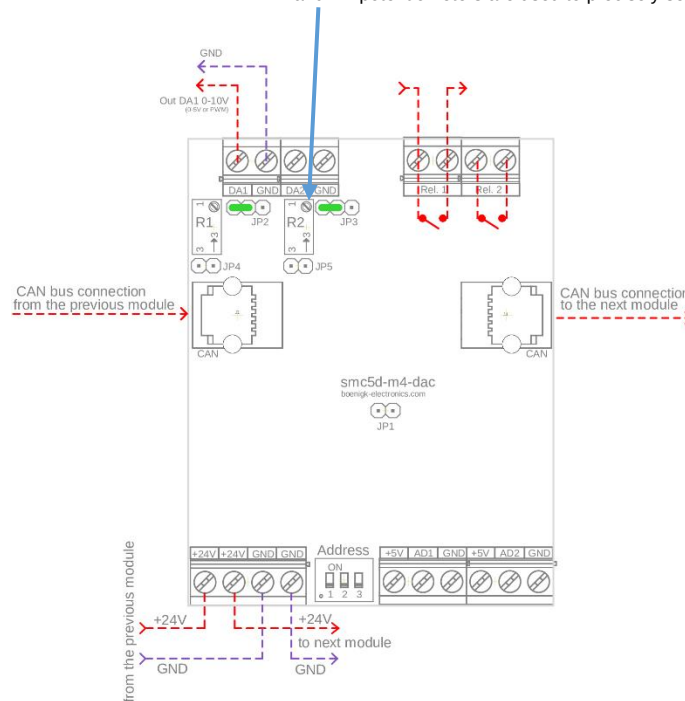

Fig. 5 View of the front panel of the dac





Jumpers	default settings	
JP1	<input checked="" type="checkbox"/> CAN bus terminating resistor ON	<input type="checkbox"/> CAN bus terminating resistor OFF
JP2	<input checked="" type="checkbox"/> DA1 voltage output (0-10V or 0-5V according to JP4 settings)	<input type="checkbox"/> DA1 PWM output
JP3	<input checked="" type="checkbox"/> DA2 voltage output (0-10V or 0-5V according to JP5 settings)	<input type="checkbox"/> DA2 PWM output
JP4	<input type="checkbox"/> DA1 0-10V	<input checked="" type="checkbox"/> DA1 0-5V
JP5	<input type="checkbox"/> DA2 0-10V	<input checked="" type="checkbox"/> DA2 0-5V

Fig. 6 Electrical wiring diagram and jumpers settings

4. Addressing expansion modules in the smc5d-m4 system, connected via CAN bus.

The following modules can be connected to the central unit:

- up to 6 (six) io  modules each with 16 digital inputs and 20 relay outputs,
- up to 4 (four) dac  modules each with two 0-10V DC analog outputs, two relay outputs, and two 0-13V analog inputs.

The address of each module is set with dip switches  located at the bottom of the device.

Addresses for given type of modules , e.g. io, cannot be the same.

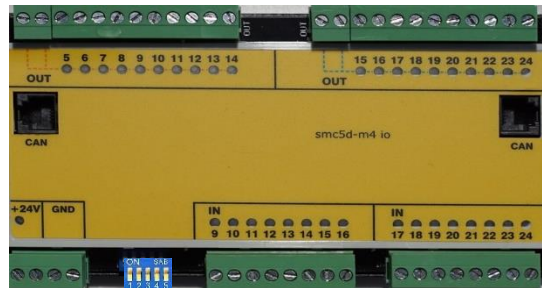







Fig. 7 Smc5d-m4 io address settings

address in the application	dip switch settings
#0	
#1	
#2	
#3	
#4	
#5	

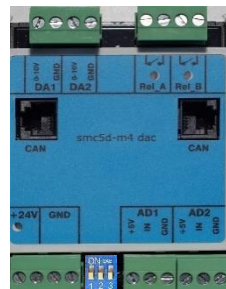



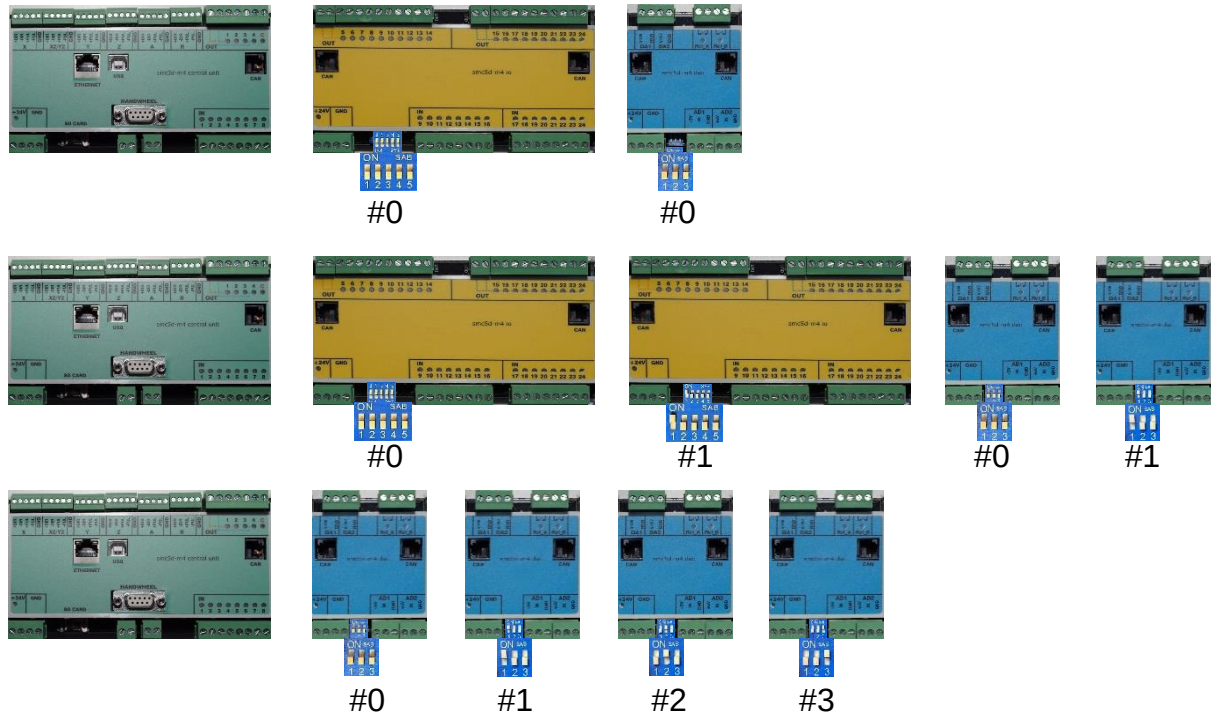

Fig. 8 Smc5d-m4 dac address settings

address in the application	dip switch settings
#0	
#1	
#2	
#3	

Examples of correct address setting



Maximum configuration

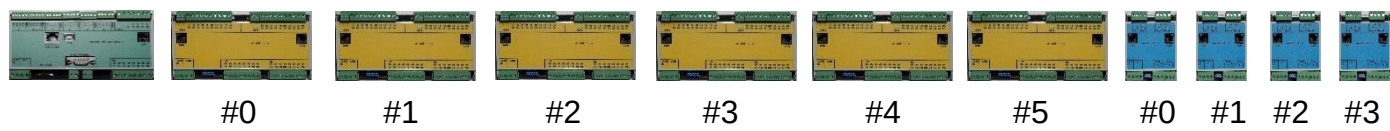

5. CAN bus termination rules

A CAN bus termination resistor must be present at the two end points of the network – see the figure below:

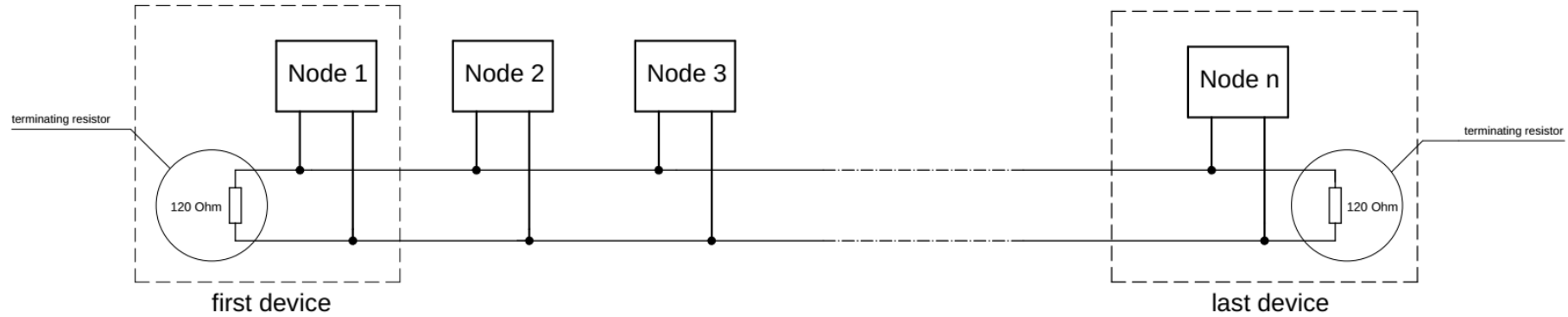

Fig. 9 Termination resistors

Each module of the smc5d-m4 system has a terminating resistor – switched with a J1 jumper.

	Termination resistor OFF
	Termination resistor ON

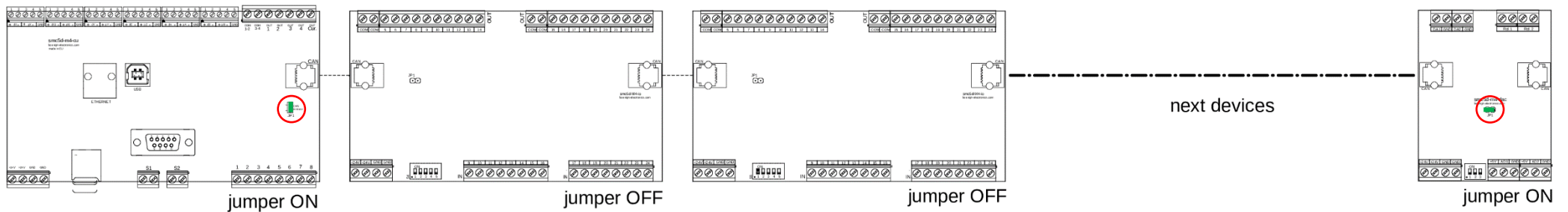

Fig. 10 Example of the correct setting of the terminating resistors